

Centre Number	Candidate Number	Name
---------------	------------------	------

UNIVERSITY OF CAMBRIDGE INTERNATIONAL EXAMINATIONS
International General Certificate of Secondary Education

CHEMISTRY

0620/02

Paper 2

May/June 2006

1 hour 15 minutes

Candidates answer on the Question Paper.
No Additional Materials are required.

READ THESE INSTRUCTIONS FIRST

Write your Centre number, candidate number and name in the spaces at the top of this page.
Write in dark blue or black pen.
You may use a pencil for any diagrams, graphs or rough working.
Do not use staples, paper clips, highlighters, glue or correction fluid.

Answer **all** questions.
A copy of the Periodic Table is printed on page 16.

At the end of the examination, fasten all your work securely together.
The number of marks is given in brackets [] at the end of each question or part question.

For Examiner's Use	
1	
2	
3	
4	
5	
6	
Total	

This document consists of **15** printed pages and **1** blank page.



1 The diagram shows models of various elements.

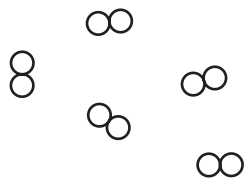

A

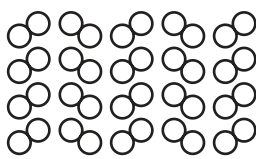

B

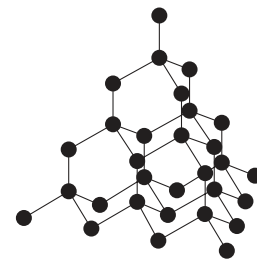

C

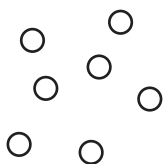

D

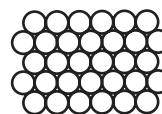

E

(a) Define the term *element*.

.....
..... [1]

(b) Which **one** of the models **A** to **E** represents a solid containing diatomic molecules?

..... [1]

(c) Which **two** of the models **A** to **E** represent gases?

..... and [1]

(d) (i) Which **one** of the models **A** to **E** represents diamond?

..... [1]

(ii) State the name of the element present in diamond.

..... [1]

(iii) State a use of diamond other than in jewellery.

..... [1]

- (e) Structure **E** is a metal. State **three** physical properties which are characteristic of all metals.

.....
.....
..... [3]

- (f) Metals are sometimes mixed with other elements in order to change their properties.

- (i) What is the name given to a mixture of metals with other elements?

..... [1]

- (ii) Match up the metals in the boxes on the left with their uses on the right. The first one has been done for you.

tin	for making chemical plants
mild steel	for plating tin cans
stainless steel	for car bodies
aluminium	for electrical wiring in houses
copper	for aircraft bodies

[4]

- 2 The diagram shows a biogas digester. Animal and vegetable waste is fermented by bacteria. The gas produced is a mixture of mainly carbon dioxide and methane.

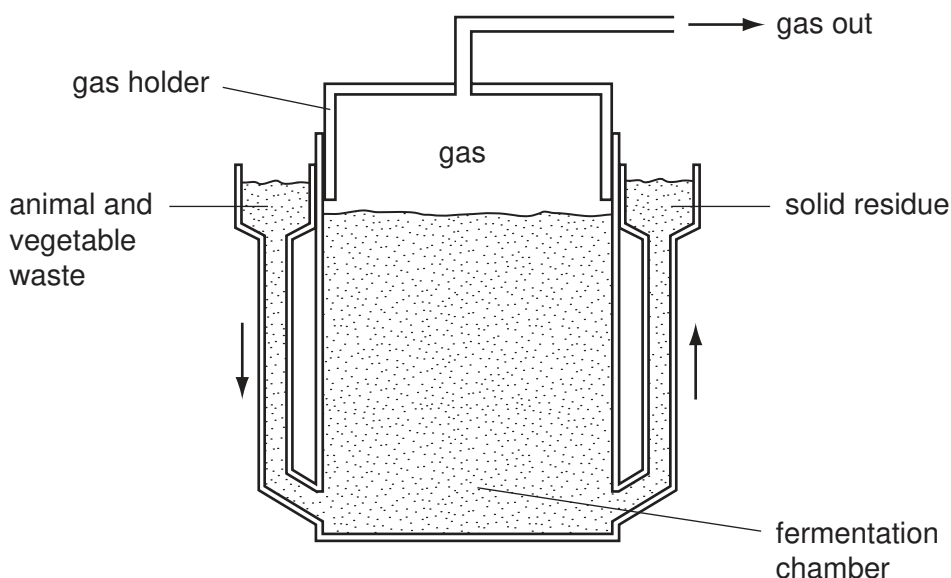

- (a) State the name given to the energy-releasing process in which organisms use food and produce carbon dioxide.

..... [1]

- (b) Hydrogen is also produced during the fermentation.
The hydrogen reacts with the carbon dioxide to form methane and oxygen.

- (i) Complete the equation for this reaction.



[2]

- (ii) Suggest a use for the methane produced in this reaction.

..... [1]

- (iii) Describe the arrangement and motion of the molecules in methane gas.

arrangement

motion [2]

- (iv) State the name of the homologous series to which methane belongs.

..... [1]

- (v) Which **one** of the following compounds belongs to the same homologous series as methane?

Tick one box.





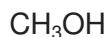



[1]

(c) Which **one** of the following equations **A**, **B**, **C** or **D** describes fermentation?

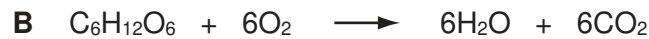
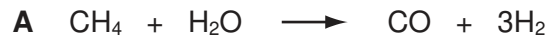

..... [1]

(d) Many of the reactions occurring in the biogas digester are catalysed by enzymes.

(i) Suggest where the enzymes come from.

..... [1]

(ii) Define the term *catalysis*.

..... [1]

(e) The solid residue from the biogas digester can be used as a fertiliser.
State the names of **two** non-metallic elements found in fertilisers which are needed for plant growth.

..... and [2]

3 The electronic structures of various atoms are shown below.

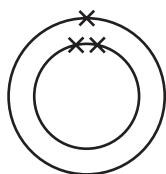

A

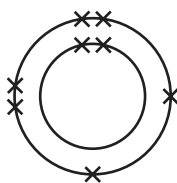

B

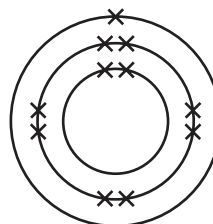

C

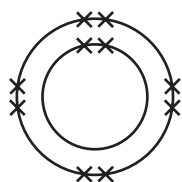

D

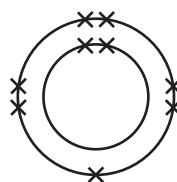

E

(a) (i) Which **one** of these structures **A** to **E** represents a noble gas?

..... [1]

(ii) Which **two** of these structures represent atoms from the same Group of the Periodic Table?

..... and [1]

(iii) Which **one** of these structures represents an atom with an atomic number of 8?

..... [1]

(iv) Which **one** of these structures forms a stable ion by gaining one electron?

..... [1]

(v) Which **one** of these structures is in Period 3 of the Periodic Table?

..... [1]

(b) Complete the following sentences using words from the list.

chlorine diamond high low sharing
sodium strong transfer weak

Covalent bonds are formed by the of pairs of electrons. Simple covalent molecules such as and bromine have melting points. Giant covalent structures such as have many bonds and have high melting points. [5]

(c) The simplest covalent molecule is hydrogen.

(i) Draw a diagram to show how the electrons are arranged in a hydrogen molecule.

(ii) Describe a test for hydrogen. [1]

test

result [2]

- 4 Coal gas is made by heating coal in the absence of air.
The table shows the composition of coal gas.

name of gas	% of gas in coal gas
hydrogen	50
methane	30
carbon monoxide	7
carbon dioxide	4
nitrogen	4
ethene	3
oxygen	2

- (a) (i) Which element in this table is a highly flammable gas?

..... [1]

- (ii) Which compound in the table is an alkene?

..... [1]

- (iii) Which compound in the table turns limewater milky?

..... [1]

- (b) Describe a test you can use to distinguish between ethene and methane.

test

result with ethene

result with methane [3]

(c) Molecules of ethene can react with each other to make poly(ethene).

(i) What is the name given to this type of reaction?

..... [1]

(ii) Which formula below best represents a molecule of poly(ethene)?

Tick one box.

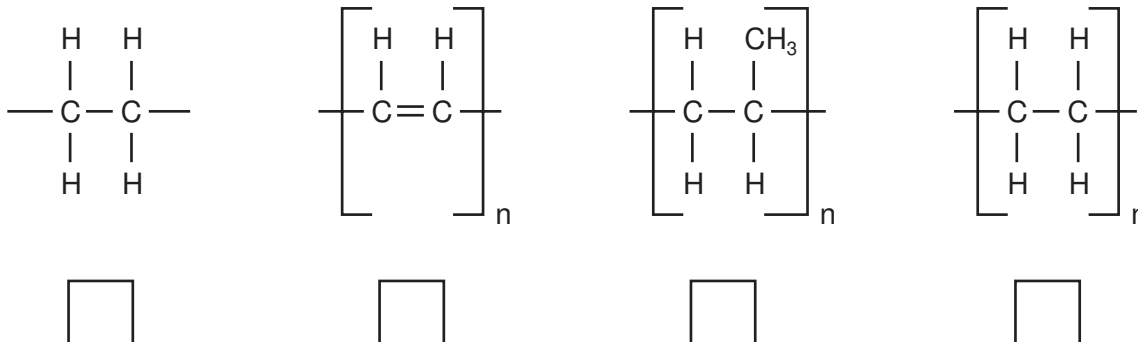

[1]

(d) Ethene can be manufactured by breaking down hydrocarbons into smaller molecules using high temperatures and a catalyst.
State the name given to this type of reaction.

..... [1]

(e) A liquid is also formed when coal is heated in the absence of air.
This liquid contains a high percentage of ammonia.

(i) Describe a test for ammonia.

test

result [2]

(ii) Ammonia has the formula NH_3 .

Calculate the relative molecular mass of ammonia.

[1]

(f) Coal contains a small amount of sulphur.
Explain why burning coal is harmful to the environment.

.....

.....

..... [2]

5 The diagram shows a cross section of a soil.

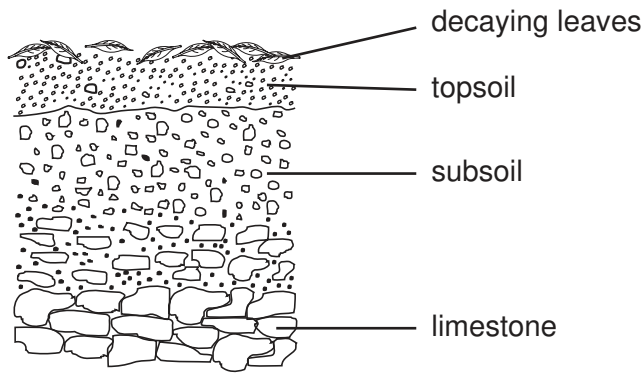

(a) A student took 10g of topsoil and shook it with 200 cm³ of distilled water.

(i) How can the student separate the solids in the soil from the solution?

..... [1]

(ii) The topsoil had a pH of 6.
Which of the following gives the best description of this pH?
Tick **one** box.

strongly acidic

weakly acidic

neutral

weakly alkaline

[1]

(b) The soil contained large amounts of calcium ions and carbonate ions.

(i) Use the information in the diagram to suggest where these ions came from.

..... [1]

(ii) Complete the word equation for the reaction of calcium carbonate with hydrochloric acid.

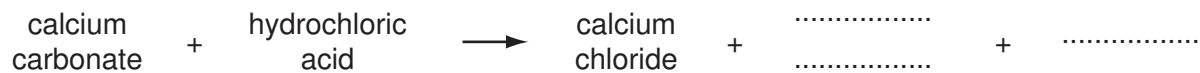

[2]

(c) The table shows the mass of each ion present in 200 cm³ of soil solution.

ion	formula of ion	mass present/milligrams
calcium	Ca ²⁺	12
carbonate	CO ₃ ²⁻	20
iron(III)	Fe ³⁺	4
magnesium	Mg ²⁺	5
nitrate	NO ₃ ⁻	2
phosphate	PO ₄ ³⁻	1
others		6

(i) Which negative ion has the highest concentration in the soil solution?

..... [1]

(ii) Calculate the mass of iron(III) ions in one litre (1000 cm³) of solution.

[1]

(iii) Which ion in the table will release ammonia when heated with aqueous sodium hydroxide and aluminium foil?

..... [1]

(iv) Describe a test for iron(III) ions.

test

result [3]

- (d) The air trapped in the soil has a different composition from the air in the atmosphere. The table shows the composition of the air in the soil.

gas	percentage of gas in soil air
carbon dioxide	2
nitrogen	82
oxygen	15
other gases	1

State how the composition of soil air compares with the composition of air in the atmosphere.

carbon dioxide

nitrogen

oxygen [3]

- (e) Decaying leaves produce ethanoic acid.
Complete the formula for ethanoic acid showing all atoms and bonds.

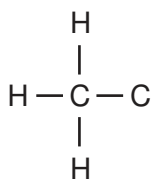

[1]

6 Iron is extracted from iron ore by heating the iron ore with coke and limestone.

(a) State the name of the ore from which iron is extracted.

..... [1]

(b) The coke burns in a blast of hot air to form carbon monoxide.

(i) Complete the equation for this reaction.



[1]

(ii) State an adverse effect of carbon monoxide on human health if it were to escape from the blast furnace.

..... [1]

(c) Near the top of the blast furnace, carbon monoxide reacts with iron ore.



(i) Write a word equation for this reaction.

[1]

(ii) What type of chemical reaction is the conversion of Fe_2O_3 to 2Fe ?

..... [1]

- (d) The limestone is converted to calcium oxide and carbon dioxide by the intense heat in the furnace.



- (i) What type of chemical reaction is this?

..... [1]

- (ii) Name a use of limestone other than in the blast furnace.

..... [1]

- (iii) The calcium oxide reacts with silica and alumina in the iron ore. The product of this reaction collects on top of the molten iron at the bottom of the furnace. What is the name of this product? Put a ring around the correct answer.

bauxite sand slag slaked lime

[1]

- (e) The iron obtained from the blast furnace contains the following impurities.

carbon manganese phosphorus silicon

- (i) Which **one** of these elements is a transition element?

..... [1]

- (ii) What type of oxide is phosphorus oxide? Put a ring around the correct answer.

acidic amphoteric basic neutral

[1]

- (iii) 50 tonnes of impure cast iron from the blast furnace contains 47 tonnes of iron. Calculate the percentage of the impurities in the cast iron.

[1]

Permission to reproduce items where third-party owned material protected by copyright is included has been sought and cleared where possible. Every reasonable effort has been made by the publisher (UCLES) to trace copyright holders, but if any items requiring clearance have unwittingly been included, the publisher will be pleased to make amends at the earliest possible opportunity.

University of Cambridge International Examinations is part of the University of Cambridge Local Examinations Syndicate (UCLES), which is itself a department of the University of Cambridge.

DATA SHEET
The Periodic Table of the Elements

Group														
I	II	III	IV	V	VI	VII	0							
7 Li Lithium 3	9 Be Beryllium 4	1 H Hydrogen 1	11 B Boron 5	12 C Carbon 6	14 N Nitrogen 7	16 O Oxygen 8	19 F Fluorine 9	20 Ne Neon 10	4 He Helium 2					
23 Na Sodium 11	24 Mg Magnesium 12	27 Al Aluminium 13	28 Si Silicon 14	31 P Phosphorus 15	32 S Sulphur 16	35.5 Cl Chlorine 17	40 Ar Argon 18							
39 K Potassium 19	40 Ca Calcium 20	45 Sc Scandium 21	51 V Vanadium 23	59 Co Cobalt 27	64 Cu Copper 29	65 Zn Zinc 30	70 Ga Gallium 31	73 Ge Germanium 32	75 As Arsenic 33	79 Se Selenium 34	84 Kr Krypton 36			
85 Rb Rubidium 37	88 Sr Strontium 38	89 Y Yttrium 39	93 Nb Niobium 41	56 Fe Iron 26	59 Ni Nickel 28	112 Cd Cadmium 48	115 In Indium 49	119 Sn Tin 50	122 Sb Antimony 51	128 Te Tellurium 52	131 Xe Xenon 54			
133 Cs Caesium 55	137 Ba Barium 56	139 La Lanthanum 57	181 Ta Tantalum 73	101 Ru Ruthenium 44	106 Pd Palladium 46	201 Hg Mercury 80	204 Tl Thallium 81	207 Pb Lead 82	209 Bi Bismuth 83	210 Po Polonium 84	222 Rn Radon 86			
226 Ra Radium 88	227 Ac Actinium 89	140 Ce Cerium 58	141 Pr Praseodymium 59	144 Nd Neodymium 60	150 Sm Samarium 62	157 Gd Gadolinium 64	162 Dy Dysprosium 66	165 Ho Holmium 67	167 Er Erbium 68	169 Tm Thulium 69	175 Lu Lutetium 71			
		232 Th Thorium 90	238 U Uranium 92	238 Np Neptunium 93	238 Pu Plutonium 94	238 Am Americium 95	238 Cm Curium 96	238 Bk Berkelium 97	238 Cf Californium 98	238 Es Einsteinium 99	238 Fm Fermium 100	238 Md Mendelevium 101	238 No Nobelium 102	238 Lr Lawrencium 103

*58-71 Lanthanoid series
190-103 Actinoid series

Key

a	X
b	

 a = relative atomic mass
 X = atomic symbol
 b = proton (atomic) number

The volume of one mole of any gas is 24 dm³ at room temperature and pressure (r.t.p.).